



Standard Test Method for Determining Activity and Selectivity of Fluid Catalytic Cracking (FCC) Catalysts by Microactivity Test¹

This standard is issued under the fixed designation D5154; the number immediately following the designation indicates the year of original adoption or, in the case of revision, the year of last revision. A number in parentheses indicates the year of last reapproval. A superscript epsilon (ϵ) indicates an editorial change since the last revision or reapproval.

1. Scope

1.1 This test method covers determining the activity and selectivity of either equilibrium or laboratory deactivated fluid catalytic cracking (FCC) catalysts. The activity is evaluated on the basis of mass percent conversion of gas oil in a microactivity unit. The selectivities are evaluated on the basis of mass percent yields of specifically defined products resulting from the catalytic cracking of gas oil.

1.2 The values stated in inch-pound units are to be regarded as standard. The values given in parentheses are mathematical conversions to SI units that are provided for information only and are not considered standard.

1.2.1 *Exception*—SI units have been retained in some of the figures.

1.3 *This standard does not purport to address all of the safety concerns, if any, associated with its use. It is the responsibility of the user of this standard to establish appropriate safety and health practices and determine the applicability of regulatory limitations prior to use.*

2. Referenced Documents

2.1 ASTM Standards:²

[D2887 Test Method for Boiling Range Distribution of Petroleum Fractions by Gas Chromatography](#)

[D3907 Test Method for Testing Fluid Catalytic Cracking \(FCC\) Catalysts by Microactivity Test](#)

[D4463 Guide for Metals Free Steam Deactivation of Fresh Fluid Cracking Catalysts](#)

[E105 Practice for Probability Sampling of Materials](#)

[E177 Practice for Use of the Terms Precision and Bias in ASTM Test Methods](#)

[E456 Terminology Relating to Quality and Statistics](#)

¹ This test method is under the jurisdiction of ASTM Committee D32 on Catalysts and is the direct responsibility of Subcommittee D32.04 on Catalytic Properties.

Current edition approved April 1, 2010. Published May 2010. Originally approved in 1991. Last previous edition approved in 2005 as D5154–05. DOI: 10.1520/D5154-10.

² For referenced ASTM standards, visit the ASTM website, www.astm.org, or contact ASTM Customer Service at service@astm.org. For *Annual Book of ASTM Standards* volume information, refer to the standard's Document Summary page on the ASTM website.

[E691 Practice for Conducting an Interlaboratory Study to Determine the Precision of a Test Method](#)

3. Terminology

3.1 Definitions of Terms Specific to This Standard:

3.1.1 *activity*—calculated as conversion divided by the difference of 100 minus conversion.

3.1.2 *ASTM reference catalysts*—a set of equilibrium FCC catalysts within the useful range of this test method is used to improve the reproducibility of test results between different laboratories. Each catalyst has a consensus mean conversion value assigned to it by Committee D32. Samples of the ASTM reference catalysts can be obtained through NIST.

3.1.3 *ASTM standard feed*—a specific batch of gas oil that is used as feedstock in the described test method.³

3.1.4 *catalyst/oil (C/O) ratio*—the mass of catalyst used in the test divided by the mass of feed fed to the reactor. In practice, the mass of catalyst is usually maintained at a constant value and the total mass of feed is varied.

3.1.5 *contact time*—calculated as $3600/(\text{WHSV} \cdot \text{C/O})$. This is the delivery time, in seconds, during which feed is introduced to the reactor.

3.1.6 *HCO*—the heavy cycle oil product defined to have a minimum boiling point of 650°F (343°C).

3.1.7 *LCO*—the light cycle oil product defined to have a boiling point range of 421 to 650°F (216 to 343°C).

3.1.8 *measured conversion*—calculated as the difference between the mass of feed used and the mass of unconverted material divided by the mass of feed used times 100%. The unconverted material is defined as all liquid product with a boiling point above 42°F (216°C).

3.1.9 *normalized product yield*—the result obtained when each product yield has been corrected for non-perfect mass balances. For a run to be judged acceptable, the total recovery, wt % of feed, should be in the range of 96 to 101% prior to normalization. If the recovery is outside this range the test data should be discarded.

³ Available from National Institute of Standards and Technology (NIST), 100 Bureau Dr., Stop 1070, Gaithersburg, MD 20899-1070, <http://www.nist.gov>.

3.1.10 *product yield*—one hundred times the mass of a specific product divided by the mass of feed used in the test.

3.1.11 *reaction severity*—an indication of the severity of the cracking reaction which allows a range of conversions to be obtained from any particular catalyst without changing reactor temperature. Changing reaction severity is achieved by changing WHSV or C/O ratio or both.

3.1.12 *weight hourly space velocity (WHSV)*—the oil feed rate in grams per hour divided by the mass of catalyst in grams. Units are hr^{-1} .

4. Summary of Test Method

4.1 At least two samples of FCC catalysts, one of which is chosen as a reference, are separately contacted with gas oil (ASTM Standard Feed or other suitable feedstock) in a fixed bed reactor at a specified reaction temperature and at more than one reaction severity. Reaction products (liquid, gas, and coke on catalyst) are analyzed. Conversion, activity, and product yields are calculated for each experiment.

4.2 Following analysis of the products, the total recovery (that is, mass balance) of the feed as converted and unconverted products is determined. If the recovery is less than 96 % or greater than 101 %, the test is rejected as unsatisfactory.

4.3 For each catalyst tested, normalized product yields are plotted against conversion or activity to generate a yield curve. The data comprising the yield curve may be used to obtain the parameters of an appropriate mathematical expression for the curve. Comparisons among catalysts can be made by interpolating the yield curves to obtain the product yields at some specified conversion.

5. Significance and Use

5.1 The microactivity test provides data to assess the relative performance of FCC catalysts. Because results are affected by catalyst pretreatment, feedstock characteristics, test equipment, and operating parameters, adherence to this test method is a prerequisite for correct interpretation of results. Apparatus, test conditions, and analytical procedures actually used should closely resemble those described in this test method. Significant variations in apparatus, test conditions and/or analytical procedures may result in activity and selectivity data which do not correlate with data developed by other laboratories on identical catalyst/feedstock samples.

5.2 The standard method reaction temperature is 960°F (516°C). Other reaction temperatures can be used; however, catalyst selectivity data developed at temperatures other than 960°F (516°C) may not correlate with selectivity data developed at 960°F (516°C). Also, precision at other reaction temperatures may change compared to data obtained at 960°F (516°C).

6. Apparatus

6.1 The apparatus of this test method is essentially that described in Test Method D3907, as shown in Figs. 1-4, with the addition of a gas collection system on the effluent gas vent line. In a typical gas collection system, a fluid is displaced by the collected gas and the volume of displaced liquid provides

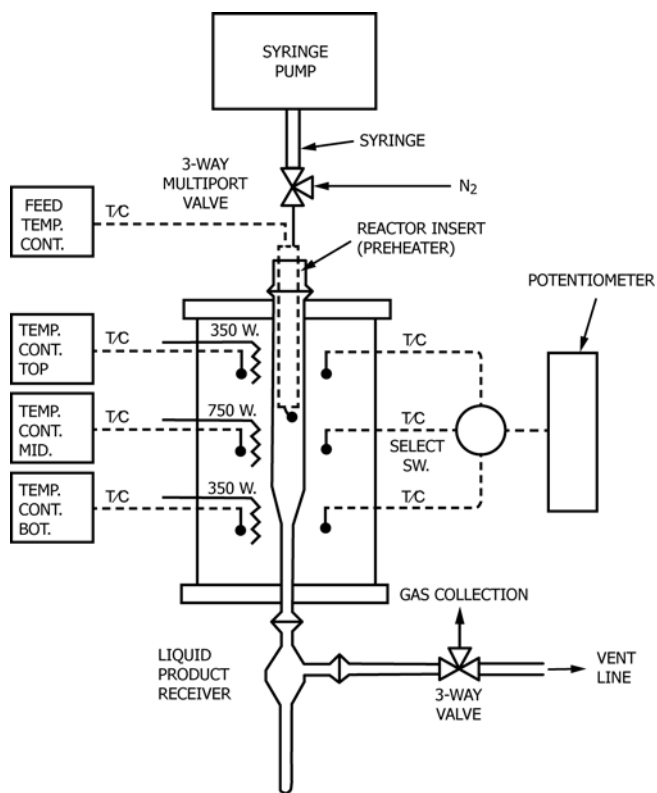

NOTE 1—This drawing is not to scale. For engineering details, see other drawings.

FIG. 1 Microactivity Flow Chart

a quantitative measurement of the amount of gas collected. To minimize the solubility of gases like H_2 and H_2S in the fluid, a saturated brine (NaCl) solution is recommended. Some publications have appeared which give example flow schematics and more detailed descriptions of typical apparatus.⁴ Alternatively, there are several vendors as listed in Research Report RR:D32-1030⁵ who can provide specific equipment for performing this test. However, Committee D32 can only suggest and will not recommend nor certify any specific vendor. Significant variations from the test apparatus of this method most likely will result in significantly different activity and selectivity data from identical catalyst samples.

6.2 Chromatographic Equipment:

6.2.1 Liquid product analyses should be performed using Test Method D2887 on a gas chromatograph (G.C.) equipped with a flame ionization detector.

6.2.2 Gas product analyses may be accomplished in two parts. First, an analysis using a G.C. equipped with a thermal conductivity detector, employing N_2 as a carrier gas, and using a G.C. column that permits the separation and quantitative identification of H_2 and H_2S . Second, an analysis using a G.C. equipped with a FID or TCD, employing He as a carrier gas and using a column that permits the separation and quantitative identification of methane, ethane, ethylene, propane,

⁴ Campagna, R. J., Wick, J. P., Brady, M. F., and Fort, D. L., "Fresh FCC Catalyst Tests Predict Performance," *OGJ*, March 24, 1986, p. 85.

⁵ Supporting data have been filed at ASTM International Headquarters and may be obtained by requesting Research Report RR:D32-1030.

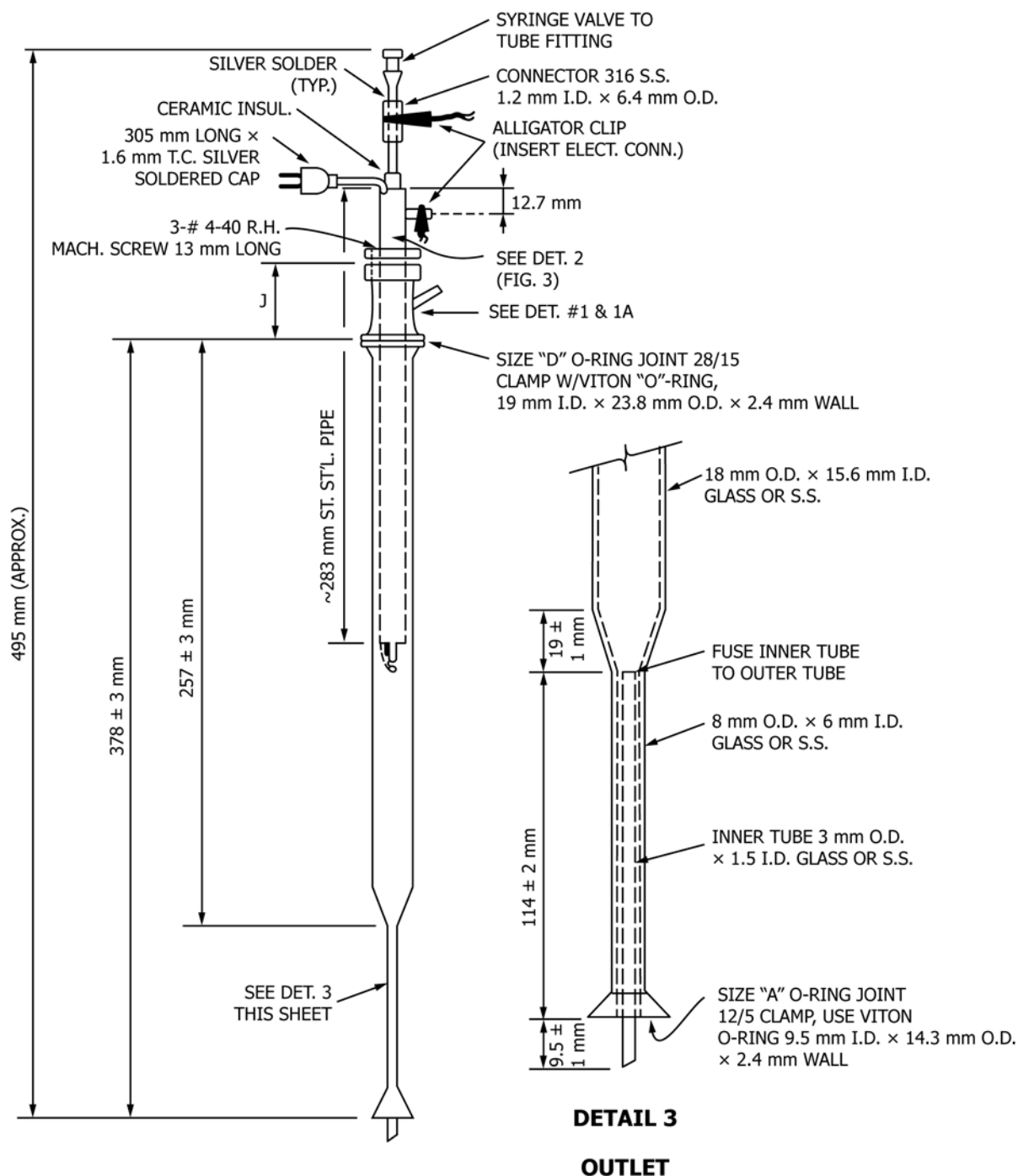

FIG. 2 Microactivity Reactor

propylene, n-butane, iso-butane, 1-butene and iso-butene, cis-2-butene, and trans-2-butene, C₅'s and a C₅⁺ lump that is not resolved. The C₅'s and the C₅⁺ group are included as part of the gasoline fraction.

6.3 Carbon analysis of a representative sample of the spent catalyst (that is, after the cracking reaction has been completed) may be accomplished using a commercially available carbon analyzer.

7. Sampling

7.1 A sampling procedure is needed. Practice E105 is appropriate.

8. Sample Preparation

8.1 *Equilibrium Catalysts*—Dry samples or decock, or both, by heating a shallow (less than 10 mm thick) bed of catalyst in a porcelain crucible at 1094 ± 36°F (590 ± 20°C) for a length